

Thread profile is ANSI 45°/7° buttress thread with pitch of five threads per inch.

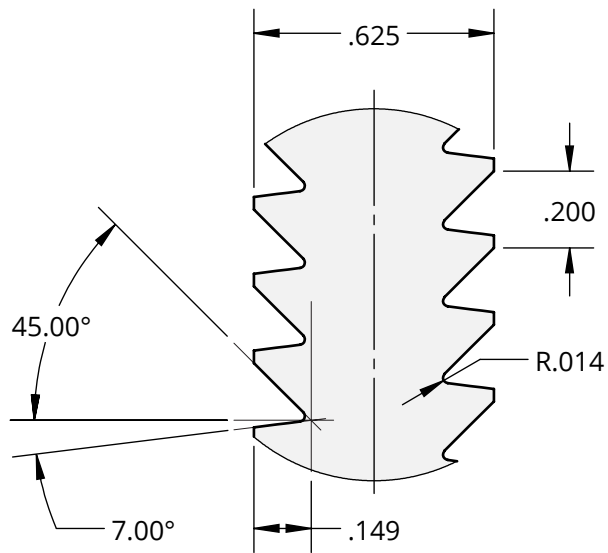

Bolt

90.00° countersink on both ends of nut to .750 diameter provides lead-in chamfer, makes threading the nut onto the bolt easier.

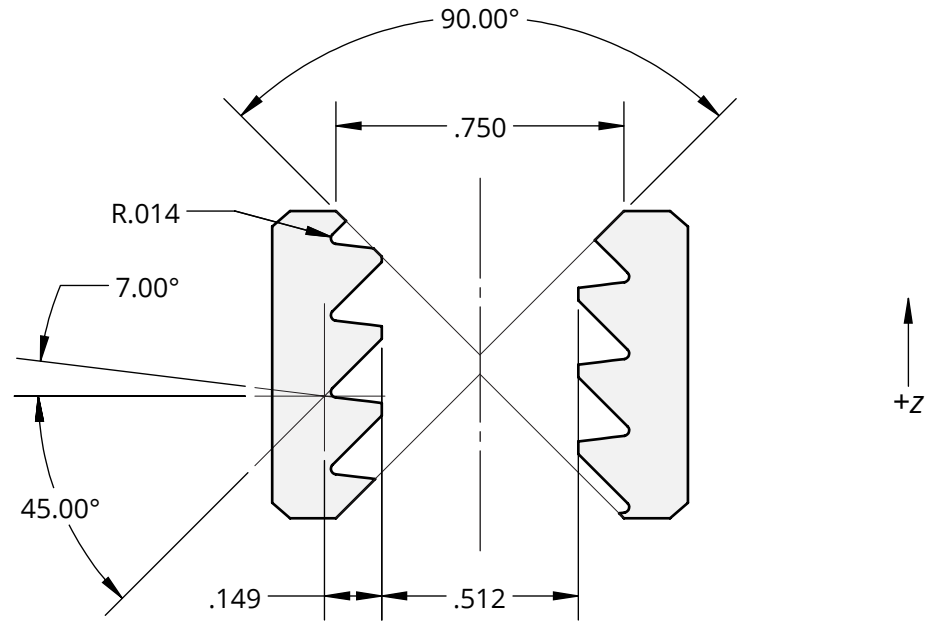

Nut

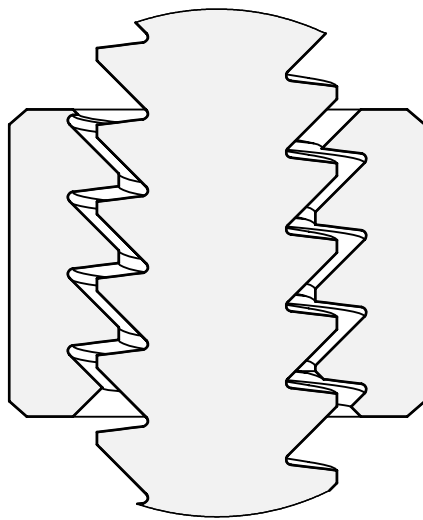

As assembled

Nut and Bolt Cross-Sections Suitable for 3D Printing

Rev. 0

Eiki Martinson, November 2012
<http://eikimartinson.com>